



FERVE

F-2013

FERVE

FERVE





- E** El catálogo FERVE 2013 reúne los mejores productos al servicio de la batería de automoción, con una amplia variedad de cargadores, comprobadores, arrancadores y demás artículos con un denominador común: su calidad y el uso de la tecnología más avanzada. Esta es nuestra apuesta y la de nuestros clientes que, en los cinco continentes, confían en FERVE para el cuidado de sus baterías.
- GB** The FERVE 2013 catalogue brings together the best products at the service of vehicle batteries, with a range of chargers, testers, boosters and other items with a common denominator: their quality and their use of the latest technology. This is our commitment and the reason why our customers in all five continents have entrusted the care of their batteries to FERVE.
- F** Le catalogue FERVE 2013 réunit les meilleurs produits au service de la batterie automobile avec une large variété de chargeurs, vérificateurs, démarreurs et autres articles avec un dénominateur commun : leur qualité et l'utilisation de la technologie la plus avancée. C'est là notre enjeu et celui de nos clients qui, sur les cinq continents, déposent leur confiance dans FERVE pour le soin de leurs batteries.
- D** Der Katalog FERVE 2013 umfasst die besten Produkte rund um Kraftfahrzeugbatterien und bietet eine breite Palette an Lade- und Prüfgeräten, Startern sowie weiteren Artikeln mit einem gemeinsamen Nenner an: Ihre Qualität und der Einsatz modernster Technologie. Dies sind die Eigenschaften, auf die wir setzen, und unsere Kunden auf den fünf Kontinenten vertrauen für die Pflege ihrer Batterien auf FERVE.
- NL** In de FERVE 2013 catalogus staan de beste producten in dienst van de accu voor voertuigen, met een breed assortiment van laders, meters, starters en allerlei andere artikelen onder een gemeenschappelijke term: kwaliteit en gebruik van de nieuwste technologie. Dit is onze inzet en deze van onze klanten overal ter wereld, die voor het onderhoud van hun accu's vertrouwen hebben in FERVE.

FERVE IN THE WORLD SINCE 1956





- 1 ALGERIA
- 2 ANDORRA
- 3 ANGOLA
- 4 ARGENTINA
- 5 ARMENIA
- 6 AUSTRALIA
- 7 AUSTRIA
- 8 BAHRAIN
- 9 BANGLADESH
- 10 BELGIUM
- 11 BOLIVIA
- 12 BRASIL
- 13 BULGARIA
- 14 BURKINA FASO
- 15 CAMEROON
- 16 CANADA
- 17 CHILE
- 18 CHINA
- 19 COLOMBIA
- 20 CUBA
- 21 CYPRUS
- 22 CZECH REPUBLIC
- 23 DENMARK
- 24 ECUADOR
- 25 EGYPT
- 26 EQUATORIAL GUINEA
- 27 ESPAÑA
- 28 ESTONIA
- 29 ETHIOPIA
- 30 FAROE ISLANDS
- 31 FINLAND
- 32 FRANCE
- 33 FRENCH GUIANA
- 34 GERMANY
- 35 GREECE
- 36 GUADELOUPE
- 37 GUATEMALA
- 38 HONG KONG
- 39 HUNGARY
- 40 ICELAND
- 41 INDIA
- 42 INDONESIA
43. IRELAND
- 44 ISRAEL
- 45 ITALY
- 46 IVORY COAST
- 47 JAPAN
- 48 JORDAN
- 49 KOREA
- 50 KUWAIT
- 51 LAOS
- 52 LATVIA
- 53 LEBANON
- 54 LIBERIA
- 55 LIBYA
- 56 LITHUANIA
- 57 LUXEMBOURG
- 58 MADEIRA
- 59 MALI
- 60 MALAYSIA
- 61 MALDIVES
- 62 MALTA
- 63 MARTINIQUE
- 64 MAURITIUS
- 65 MÉXICO
- 66 MOROCCO
- 67 NEDERLAND
- 68 NEW CALEDONIA
- 69 NEW ZEALAND
- 70 NICARAGUA
- 71 NIGERIA
- 72 NORWAY
- 73 OMAN
- 74 PAKISTAN
- 75 PANAMÁ
- 76 PARAGUAY
- 77 PERÚ
- 78 PHILIPPINES
- 79 PORTUGAL
- 80 PUERTO RICO
- 81 QATAR
- 82 REP. DOMINICANA
- 83 RÉUNION
- 84 ROMANIA
- 85 RUSSIA
- 86 SAUDI ARABIA
- 87 SENEGAL
- 88 SERBIA
- 89 SIERRA LEONE
- 90 SINGAPORE
- 91 SLOVAKIA
- 92 SLOVENIA
- 93 SOUTH AFRICA
- 94 SRI LANKA
- 95 SUDAN
- 96 SWEDEN
- 97 SWITZERLAND
- 98 SYRIA
- 99 TAHITI
- 100 TAIWAN
- 101 TANZANIA
- 102 THAILAND
- 103 TUNISIA
- 104 TURKEY
- 105 UAE
- 106 UGANDA
- 107 UNITED KINGDOM
- 108 URUGUAY
- 109 USA
- 110 VENEZUELA
- 111 VIETNAM
- 112 YEMEN

		PAG.			PAG.
FERVE PRIMA		8	FERVE RIPPLE FREE		37
Cargadores de baterías Battery chargers Chargeurs de batteries Batterieladegeräte Acculaders			Cargadores-comprobadores de baterías Battery chargers-testers Chargeurs-vérificateurs de batteries Batterieladegeräte - Batterieprüfgeräte Acculaders-testers		
FERVE AUTOMATIC		13	FERVE BOOSTERS		39
Cargadores automáticos Automatic chargers Chargeurs automatiques Automatische Ladegeräte Automatische laders			Arrancadores Boosters Démarreurs Anlasser Starters		
FERVE DUAL		17	FERVE TESTERS		45
Cargadores automáticos Automatic chargers Chargeurs automatiques Automatische Ladegeräte Automatische laders			Aparatos de comprobación Battery testing equipment Appareils de vérification Mess und Prüfgeräte Accu testgereedeschap		
FERVE TETRA		21	FERVE CIRCUIT TEST		54
Cargadores automáticos Automatic chargers Chargeurs automatiques Automatische Ladegeräte Automatische laders			Aparatos de comprobación Battery testing equipment Appareils de vérification Mess und Prüfgeräte Accu testgereedeschap		
FERVE HF		24	FERVE PINZAS		56
Cargadores automáticos Automatic chargers Chargeurs automatiques Automatische Ladegeräte Automatische laders			Pinzas de batería Battery clamps Pincas de batteries Batterieklemmen Accuklemmen		
FERVE TEN		27	FERVE ACCESORIOS		58
Cargadores automáticos Automatic chargers Chargeurs automatiques Automatische Ladegeräte Automatische laders			Accesorios para batería Accessories for battery Accessoires pour batterie Zubehöre für Batterien Accu toebehoren		
FERVE FAST		31	FERVE ROLL-FLEX		60
Cargadores rápidos Fast chargers Chargeurs rapides Schnellladegeräte Snelladers			Cables de emergencia Battery booster cables Câbles auxiliaires de démarrage Starterkabel Startkabels		

FERVE PRIMA

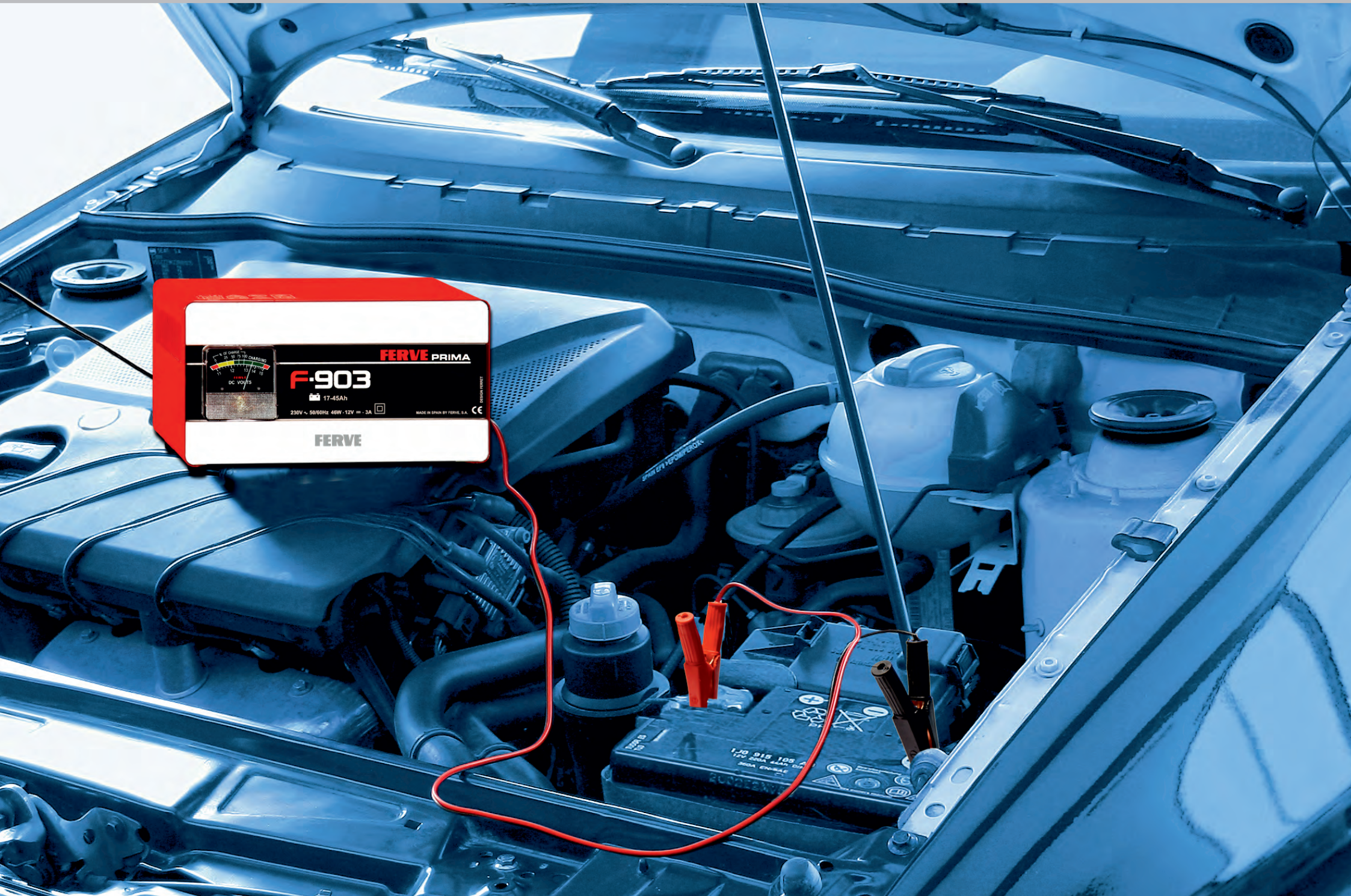



F-705

230 V ~ 50/60 Hz 46 W

6 - 12 V
1,5 - 3 A arith. 45 Ah
2 - 4,5 A eff.

150 x 90 x 135 mm
1,550 kg

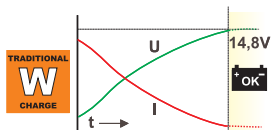

6-12V



F-903

230 V ~ 50/60 Hz 46 W

12 V
3 A arith. 45 Ah
4,5 A eff.

190 x 110 x 180 mm
1,850 kg

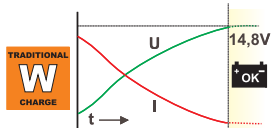

12V

TEST



F-905

230 V ~ 50/60 Hz 83 W

12 V
5 A arith. 60 Ah
7 A eff.

190 x 110 x 180 mm
2,200 kg

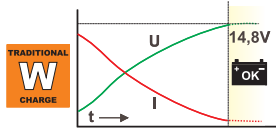

12V

TEST





F-805

230 V ~ 50/60 Hz 83 W

12 V
5 A arith. 30 60 Ah
7 A eff.

210 x 125 x 180 mm
2,460 kg

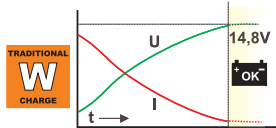

F-886

230 V ~ 50/60 Hz 115 W

12 V
4 - 8 A arith. 24 95 Ah
5,5 - 11 A eff.

210 x 125 x 180 mm
4,100 kg

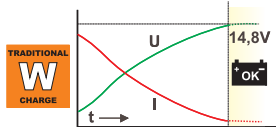

F-806

230 V ~ 50/60 Hz 115 W

12 V
4 - 8 A arith. 24 95 Ah
5,5 - 11 A eff.

210 x 125 x 180 mm
4,100 kg

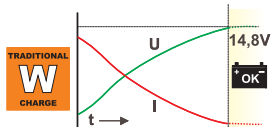



F-807

230 V ~ 50/60 Hz 210 W

12 - 24 V
4 - 8 A arith.
5,5 - 11 A eff.



24 ▲ 95 Ah

210 x 125 x 180 mm
4,230 kg

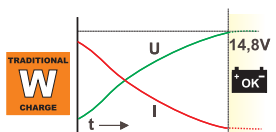

12-24V



F-811

230 V ~ 50/60 Hz 177 W

12 V
6 - 12 A arith.
8,5 - 17 A eff.



35 ▲ 140 Ah

250 x 145 x 210 mm
6,320 kg

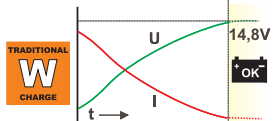

12V

TEST



F-812

230 V ~ 50/60 Hz 315 W

12 - 24 V
6 - 12 A arith.
8,5 - 17 A eff.



35 ▲ 140 Ah

290 x 170 x 240 mm
8,620 kg

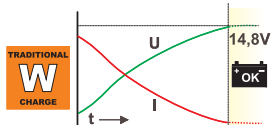

12-24V

TEST





F-915

230 V ~ 50/60 Hz 395 W

12 - 24 V
8 - 16 A arith. 50 180 Ah
11 - 22,5 A eff.

290 x 170 x 240 mm
9,400 kg

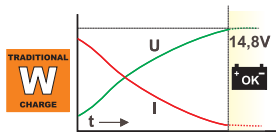

12-24V

TEST



F-918

230 V ~ 50/60 Hz 540 W

12 - 24 V
10 - 20 A arith. 80 225 Ah
14 - 28 A eff.

290 x 170 x 240 mm
11,670 kg

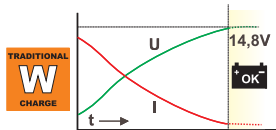

12-24V

TEST



F-930

230 V ~ 50/60 Hz 680 W

12 - 24 V
15 - 30 A arith. 105 360 Ah
21 - 43 A eff.

360 x 205 x 260 mm
16,750 kg

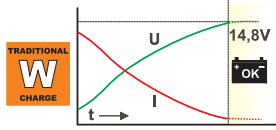

12-24V

TEST



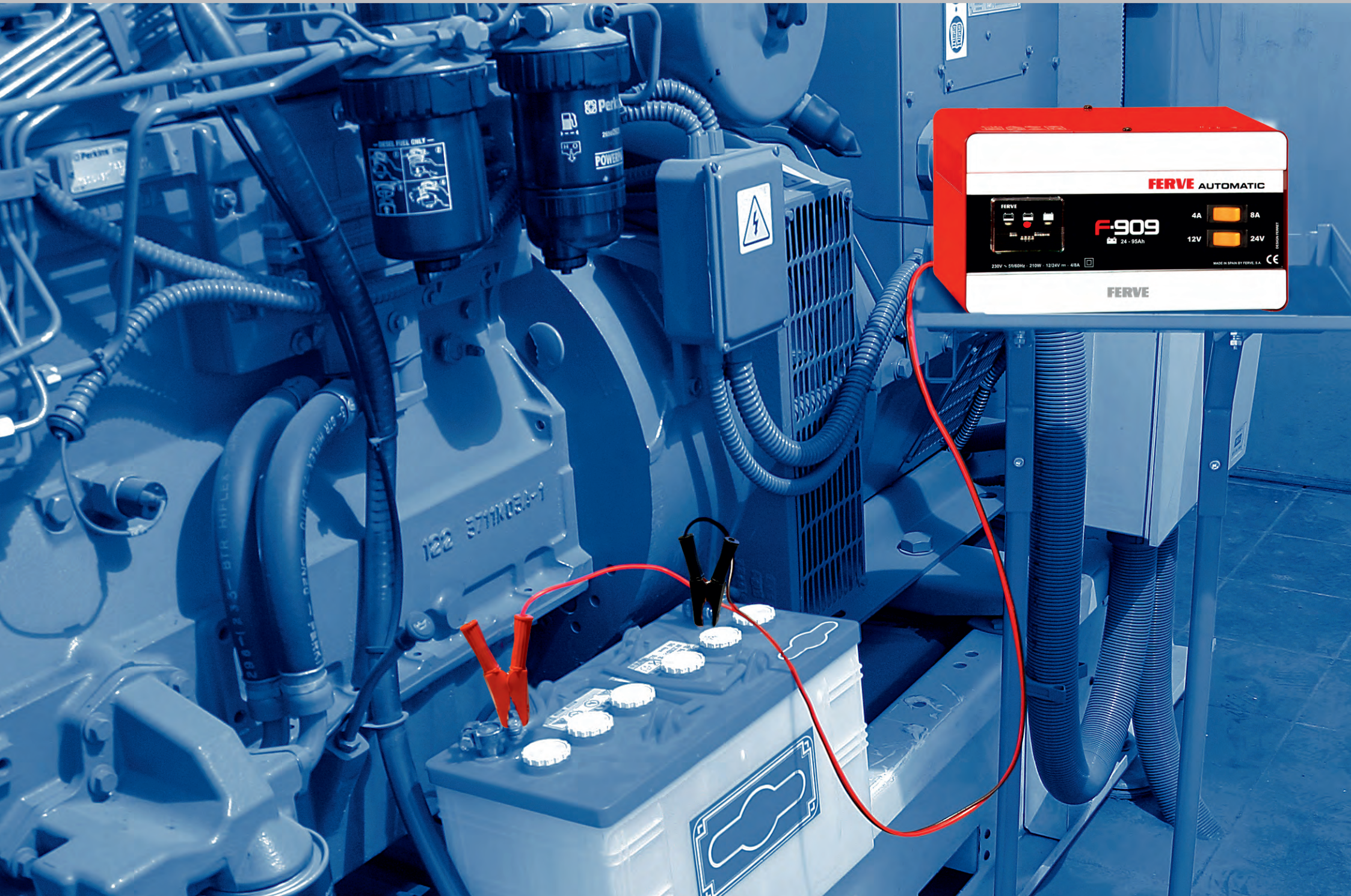

FERVE AUTOMATIC



F909
24 - 95Ah

4A 8A
12V 24V

230V ~ 50/60Hz 310W 12.24V ~ 43A

MADE IN SPAIN BY FERVE, S.A. CE

FERVE



F-2106

230 V ~ 50/60 Hz 12 W

6 V
750 mA arith.  **4**  **45 Ah**
1 A eff. **automatic**

58 x 50 x 83 mm
 0,710 kg

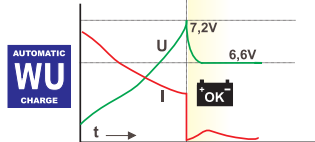

F-2201

230 V ~ 50/60 Hz 20 W

12 V
750 mA arith.  **4**  **45 Ah**
1 A eff. **automatic**

58 x 50 x 83 mm
 0,660 kg

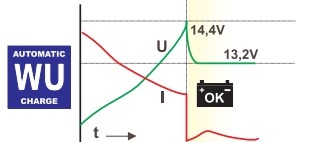

F-66

230 V ~ 50/60 Hz 46 W

12 V
3 A arith.  **17**  **45 Ah**
4,5 A eff. **automatic**

150 x 90 x 135 mm
 1,550 kg

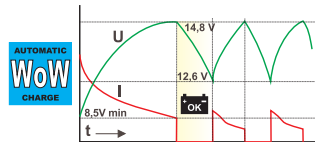



F-77

230 V ~ 50/60 Hz 166 W

12 V
5 - 10 A arith. 30 115 Ah
7 - 14 A eff. **automatic**

191 x 272 x 98 mm
4,350 kg

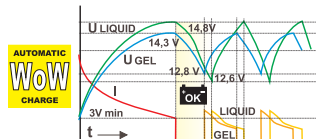

F-968

230 V ~ 50/60 Hz 115 W

6 - 12 V
4 - 8 A arith. 24 95 Ah
5,5 - 11 A eff. **automatic**

210 x 125 x 180 mm
3,500 kg

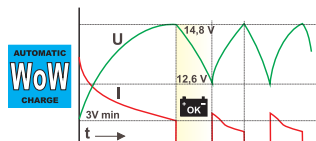

F-909

230 V ~ 50/60 Hz 210 W

12 - 24 V
4 - 8 A arith. 24 95 Ah
5,5 - 11 A eff. **automatic**

235 x 140 x 195 mm
4,770 kg

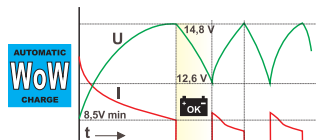



F-4005

230 V ~ 50/60 Hz 332 W

4 x 12 V
 4 x 5 A arith.
 4 x 7 A eff. **automatic**
 450 x 250 x 90 mm
 7,800 kg

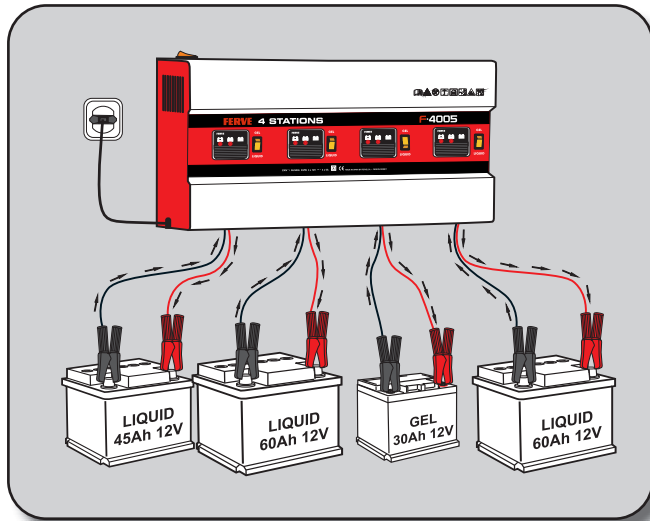
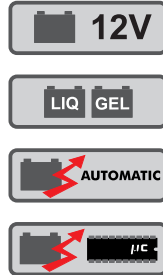
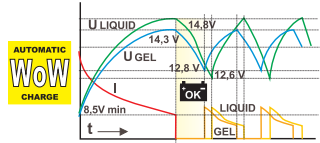

FERVE DUAL

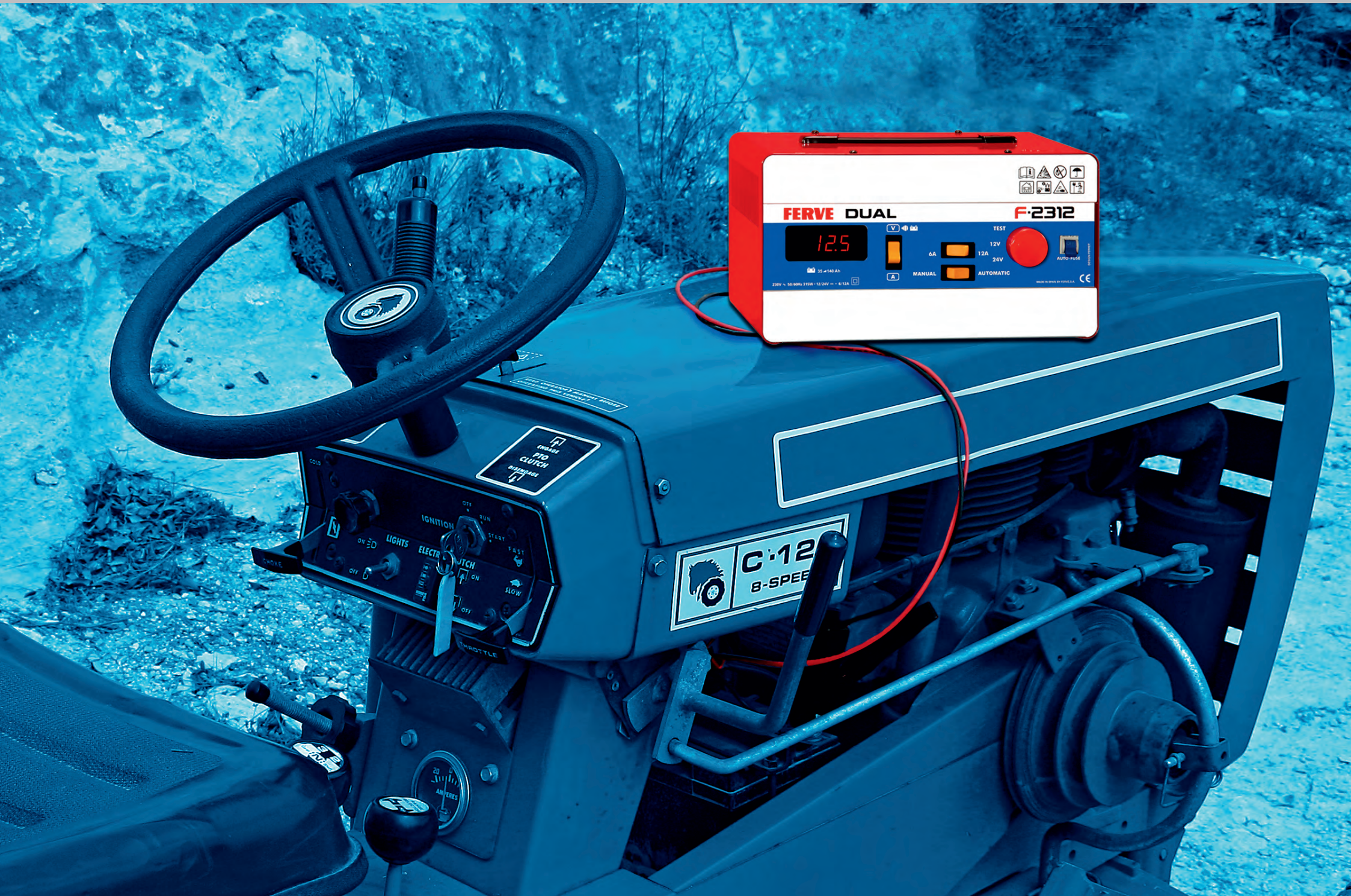
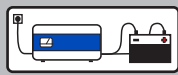

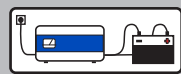

F-908

230 V ~ 50/60 Hz 115 W

12 V
4 - 8 A arith. 24 95 Ah
5,5 - 11 A eff. manual/automatic

210 x 125 x 180 mm
4,100 kg



F-2312

230 V ~ 50/60 Hz 315 W

12 - 24 V
6 - 12 A arith. 35 140 Ah
8,5 - 17 A eff. manual/automatic

290 x 170 x 240 mm
8,600 kg

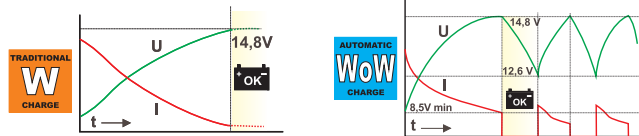

F-2316

230 V ~ 50/60 Hz 395 W

12 - 24 V
8 - 16 A arith. 50 180 Ah
11 - 22,5 A eff. manual/automatic

290 x 170 x 240 mm
9,360 kg

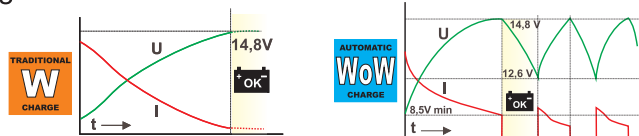

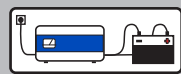

F-2320

230 V ~ 50/60 Hz 540 W

12 - 24 V
 10 - 20 A arith. 80 225 Ah
 14 - 28 A eff. manual/automatic

290 x 170 x 240 mm
 11,800 kg

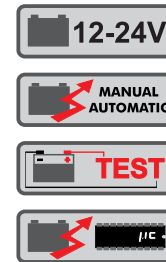

F-2330

230 V ~ 50/60 Hz 680 W

12 - 24 V
 15 - 30 A arith. 105 360 Ah
 21 - 43 A eff. manual/automatic

360 x 205 x 260 mm
 16,750 kg

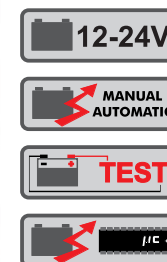

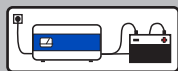

F-925 D

230 V ~ 50/60 Hz

12 V **24 V**
55 A arith. **35 A arith.**
78 A eff. **50 A eff.**

28 440 Ah

BOOSTER 250 A

23,900 kg

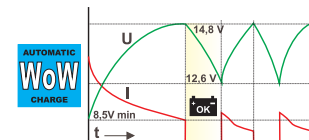
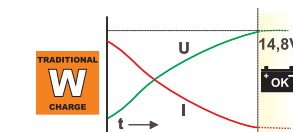
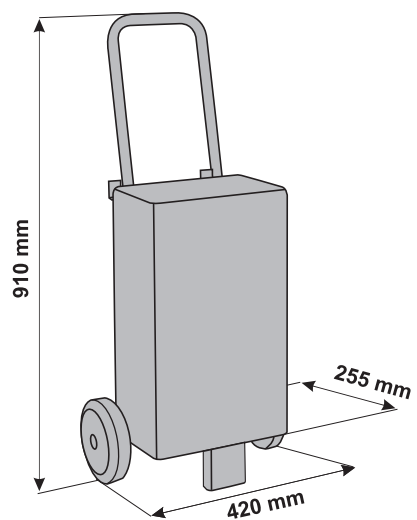

12-24V

MANUAL
AUTOMATIC

TEST

I/C

BOOSTER
250A



FERVE TETRA



VERTRETER: ZSCHOPAU

SERVICIO



F-2908

230 V ~ 50/60 Hz 210 W

12 - 24 V
4 - 8 A arith. 24 \blacktriangle 95 Ah
5,5 - 11 A eff. manual/automatic

235 x 140 x 195 mm
4,900 kg

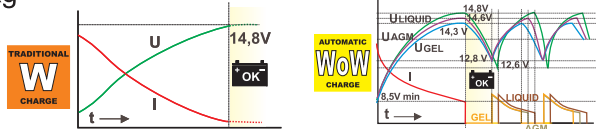

12-24V

LIQ GEL AGM

MANUAL
AUTOMATIC

IC



F-2914

230 V ~ 50/60 Hz 315 W

12 - 24 V
6 - 12 A arith. 35 \blacktriangle 140 Ah
8,5 - 17 A eff. manual/automatic

290 x 170 x 240 mm
9,050 kg

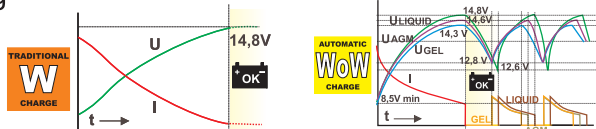

12-24V

LIQ GEL AGM

MANUAL
AUTOMATIC

IC



F-2916

230 V ~ 50/60 Hz 395 W

12 - 24 V
8 - 16 A arith. 50 \blacktriangle 180 Ah
11 - 22,5 A eff. manual/automatic

290 x 170 x 240 mm
9,350 kg

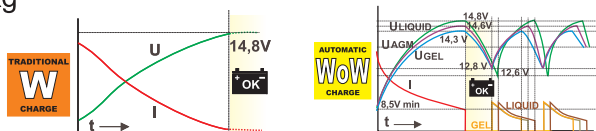

12-24V

LIQ GEL AGM

MANUAL
AUTOMATIC

IC





F-2920

230 V ~ 50/60 Hz 540 W

12 - 24 V
 10 - 20 A arith. 80 \blacktriangle 225 Ah
 14 - 28 A eff. manual/automatic

290 x 170 x 240 mm
 11,650 kg

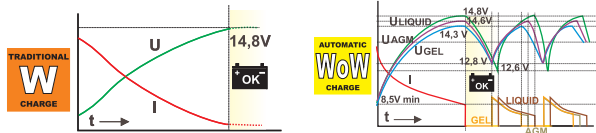

12-24V

LIQ GEL AGM

MANUAL
 AUTOMATIC

+ -



F-2930

230 V ~ 50/60 Hz 680 W

12 - 24 V
 15 - 30 A arith. 105 \blacktriangle 360 Ah
 21 - 43 A eff. manual/automatic

360 x 205 x 260 mm
 16,700 kg

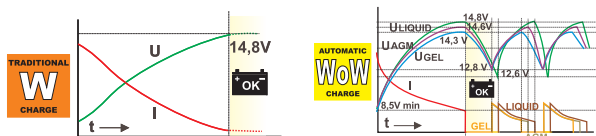

12-24V

LIQ GEL AGM

MANUAL
 AUTOMATIC

+ -



FERVE HF





F-2504

230 V ~ 50/60 Hz 65 W

12 V
 0,8 - 4 A arith.
 0,8 - 4 eff. automatic
 190 x 42 x 62 mm
 0,520 kg

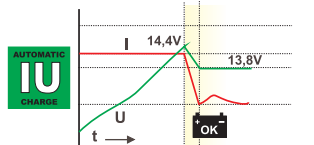

- 12V
- LIQ GEL AGM
- AUTOMATIC
- μ C
-



F-2507

230 V ~ 50/60 Hz 135 W

12 V
 7 A arith.
 7 eff. automatic
 205 x 52 x 95 mm
 0,810 kg

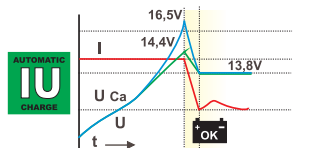

- 12V
- LIQ GEL AGM Ca
- AUTOMATIC
- μ C
-





F-2912

230 V ~ 50/60 Hz 210 W

12 V
 2 - 6 - 12 A arith.  10  200 Ah
 2 - 6 - 12 A eff. **automatic**

240 x 285 x 130 mm

2,200 kg

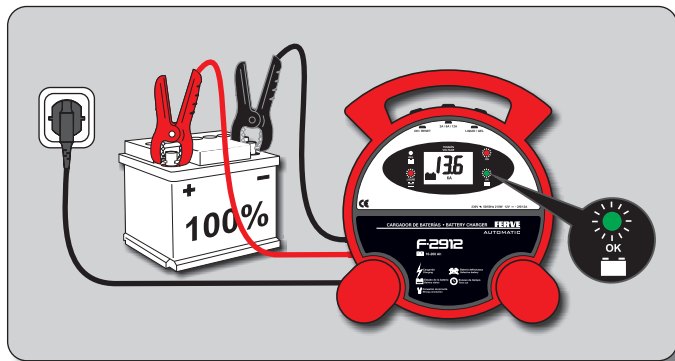
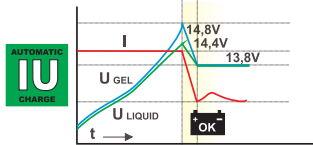

FERVE TEN

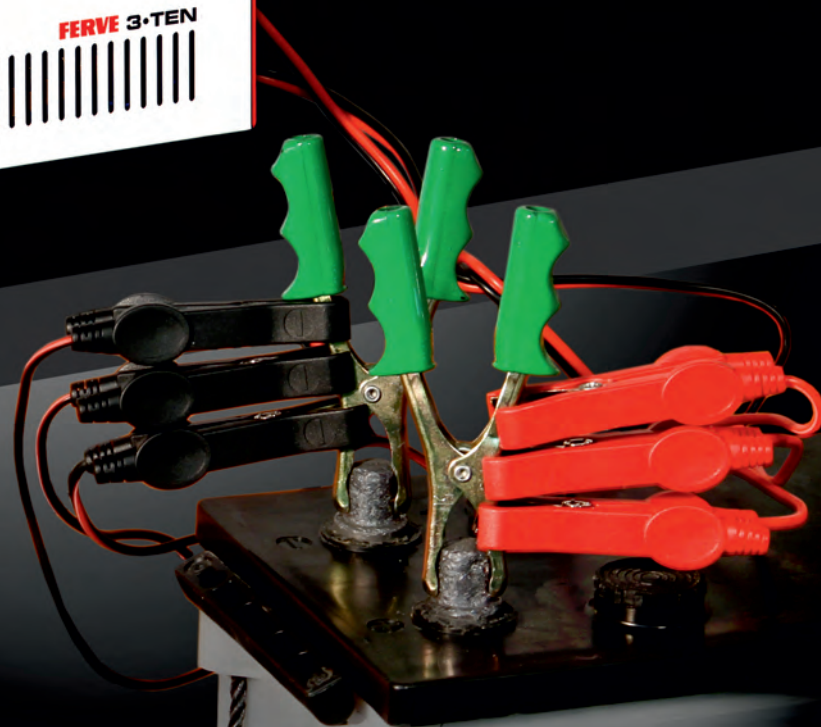
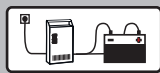

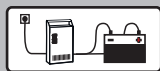

F-1210 FERVE TEN

100-240 V ~ 50/60 Hz 180 W

12 V - 10 A 45 120 Ah

117 x 205 x 45 mm

1,150 kg

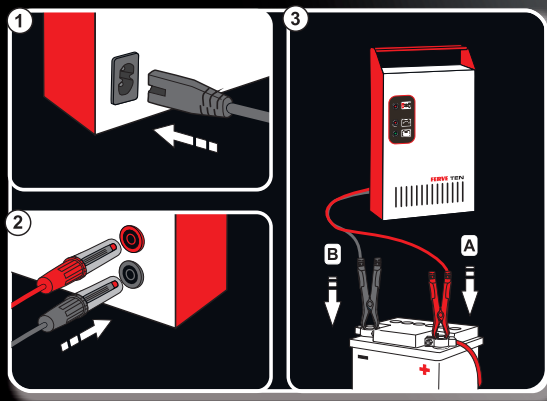

100 - 240 V
~

12V

LIQ GEL AGM

AUTOMATIC

RF



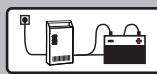

F-1220 FERVE 2•TEN

100-240 V ~ 50/60 Hz 360 W

12 V - 10 / 20 A 45 225 Ah

24 V - 10 A

201 x 205 x 45 mm

1,860 kg

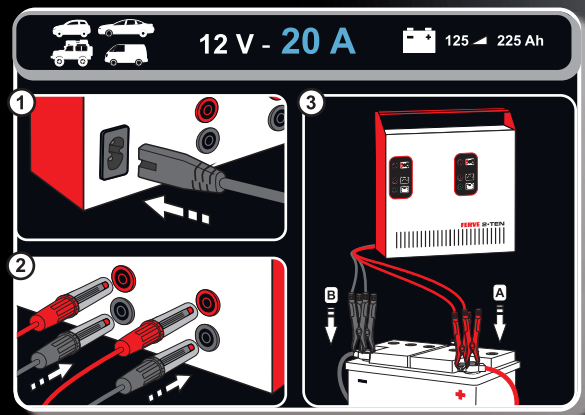
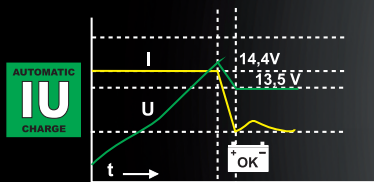

100 - 240 V

12-24V

LIQ GEL AGM

AUTOMATIC

12V - 20A
24V - 10A



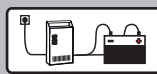

F-1230 FERVE 3•TEN

100-240 V ~ 50/60 Hz 540 W

12 V - 10 / 20 / 30 A 45 360 Ah

24 V - 10 A

230 x 235 x 45 mm

2,550 kg

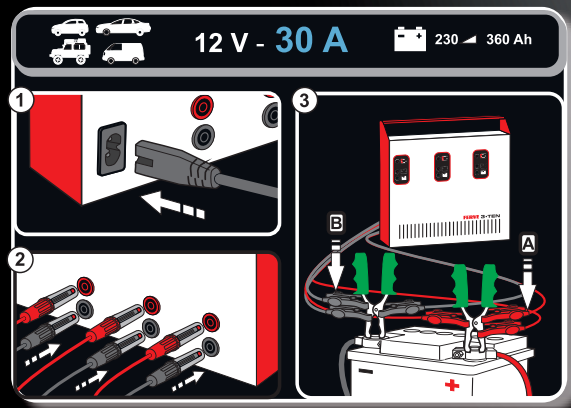
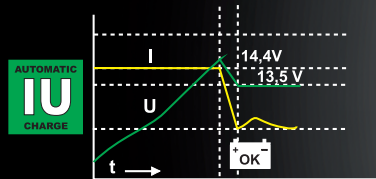

100 - 240 V

12-24V

LIQ GEL AGM

AUTOMATIC

12V - 30A
24V - 10A



FERVE FAST

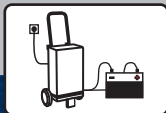

FERVE
FAST F-925



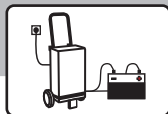

F-923

230 V ~ 50/60 Hz

12 V

40 A arith.
57 A eff.

24 V

20 A arith.
28 A eff.

20 360 Ah

BOOSTER 150 A

21,360 kg

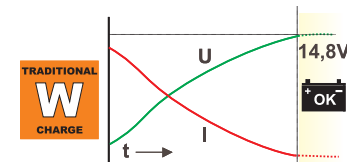
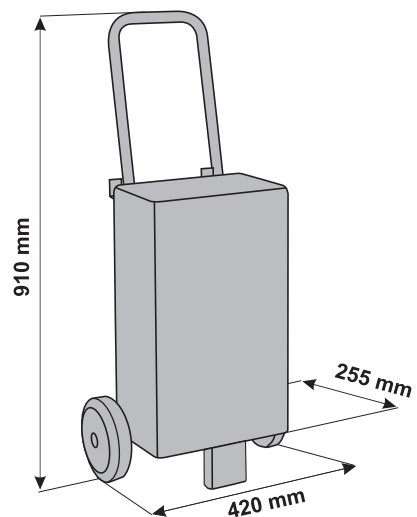

12-24V

TEST

IIC

BOOSTER
150A



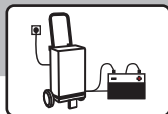

F-925

F-925 RF

230 V ~ 50/60 Hz

12 V

55 A arith.
78 A eff.

24 V

35 A arith.
50 A eff.

28 \blacktriangleleft 440 Ah

BOOSTER 250 A

23,900 kg

24,500 kg *RF*

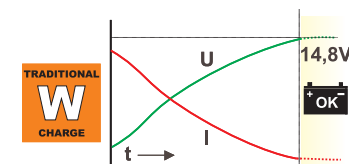
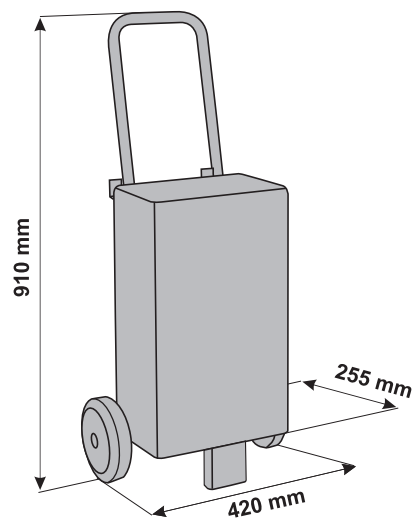

12-24V

TEST

μ C

BOOSTER 250A

RF



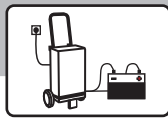

F-970

F-970 RF

230 V ~ 50/60 Hz

12 V

70 A arith.
100 A eff.

24 V

55 A arith.
78 A eff.

36 \blacktriangleleft 660 Ah

BOOSTER 450 A

27,500 kg

28,500 kg *RF*

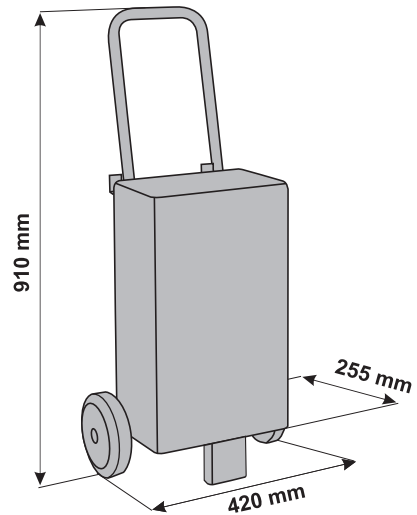

12-24V

TEST

μ C

BOOSTER
450A

RF

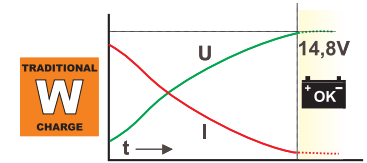

Mando a distancia para el arranque
Remote control for cranking
Commande à distance pour le démarrage
Fernbedienung für starten
Afstandsbediening voor het starten



4 m



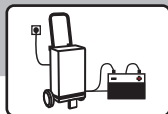

F-990 RF

230 V ~ 50/60 Hz

12 V **24 V**
100 A arith. **70 A arith.**
100 A eff. **70 A eff.**

45 1000 Ah

BOOSTER 600 A

42,550 kg automatic

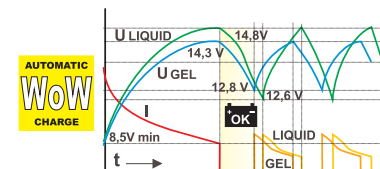
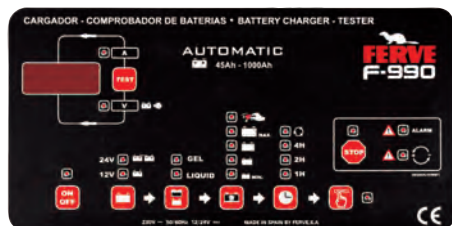
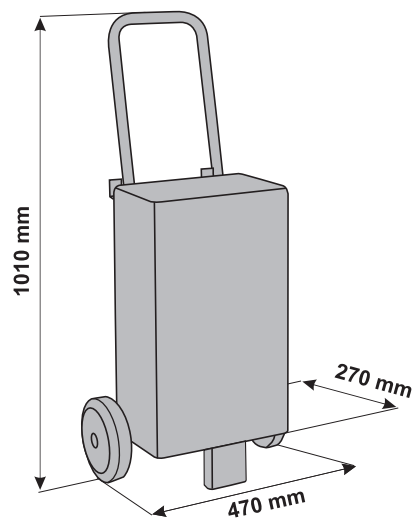

12-24V

AUTOMATIC

TEST

IIC

BOOSTER
600A

RF



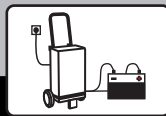

FERVE HYBRID F-9200

100-240 V ~ 50/60 Hz 540 W

12 V - 30 A

BOOSTER 600 A

1500 A pico / peak

12 V - 28 Ah

25 mm² 600 A

20,900 kg

NUEVO
 NEW

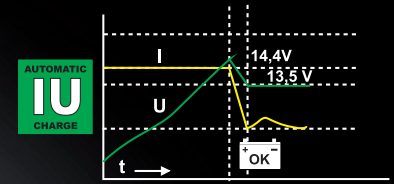

100 - 240 V

12V

LIQ GEL AGM

45 Ah 360 Ah

AUTOMATIC

BOOSTER 600A

RF

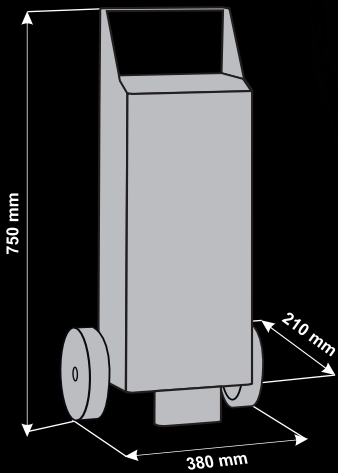
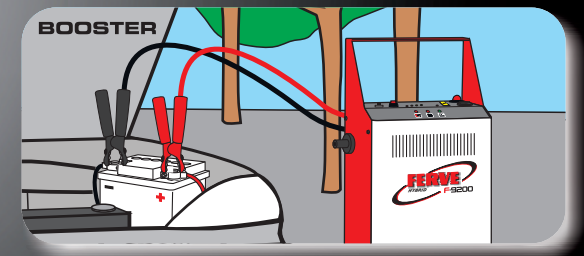
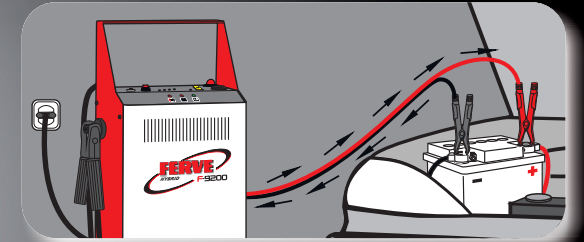

FERVE RIPPLE FREE

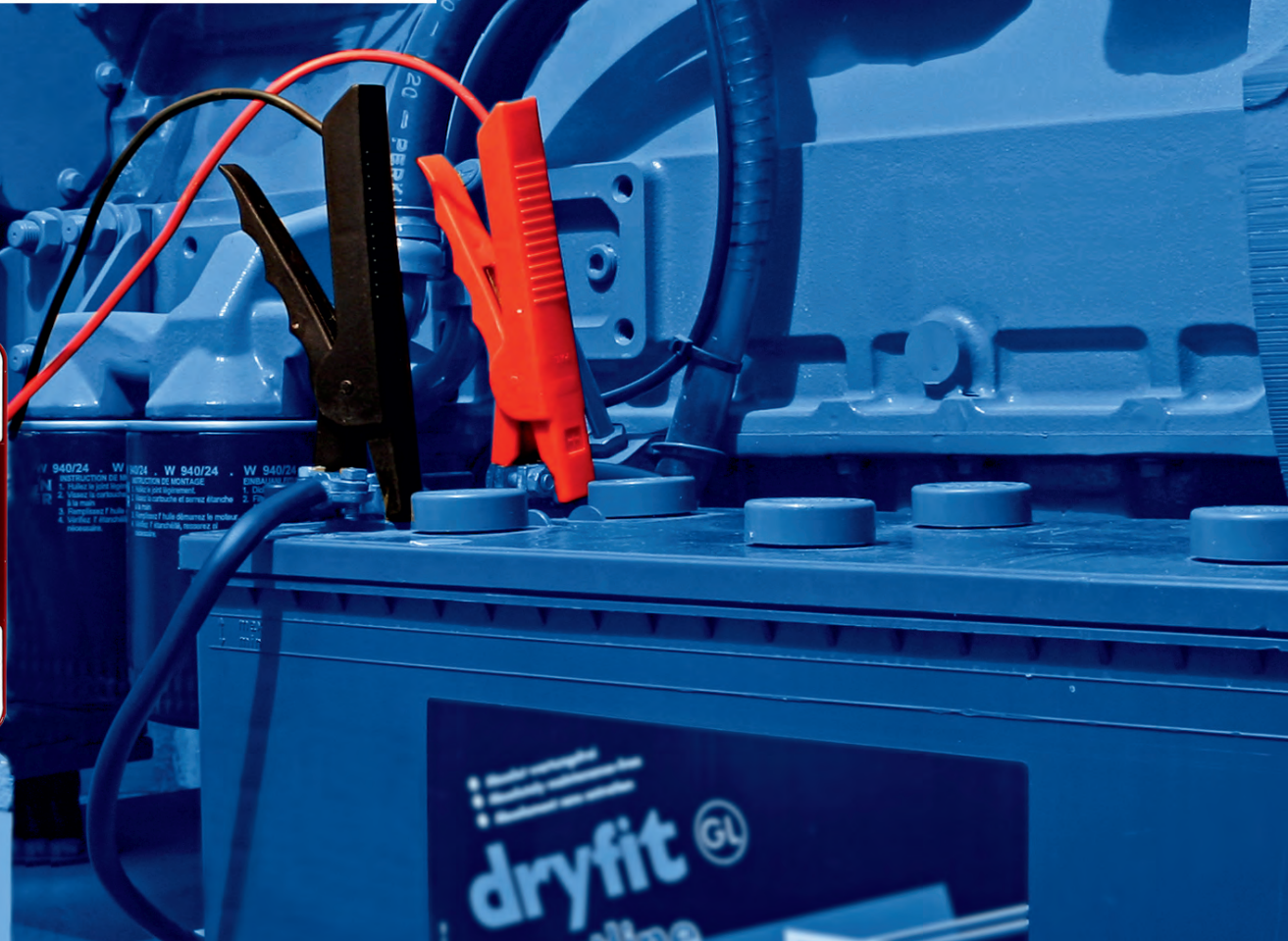
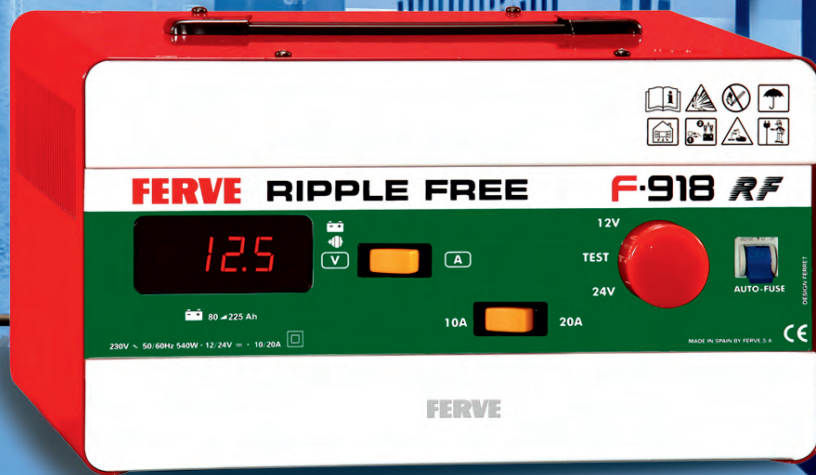



F-812 RF

230 V ~ 50/60 Hz 315 W

12 - 24 V  35  140 Ah
6 - 12 A arith.
6 - 12 A eff.

290 x 170 x 240 mm
8,850 kg

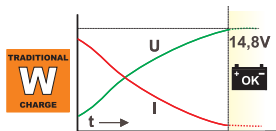

 12-24V

 TEST

 RF



F-915 RF

230 V ~ 50/60 Hz 395 W

12 - 24 V  50  180 Ah
8 - 16 A arith.
8 - 16 A eff.

290 x 170 x 240 mm
9,700 kg

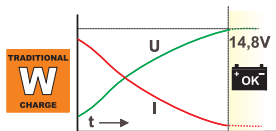

 12-24V

 TEST

 RF



F-918 RF

230 V ~ 50/60 Hz 540 W

12 - 24 V  80  225 Ah
10 - 20 A arith.
10 - 20 A eff.

290 x 170 x 240 mm
12,100 kg

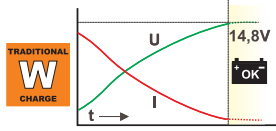

 12-24V

 TEST

 RF



FERVE BOOSTERS

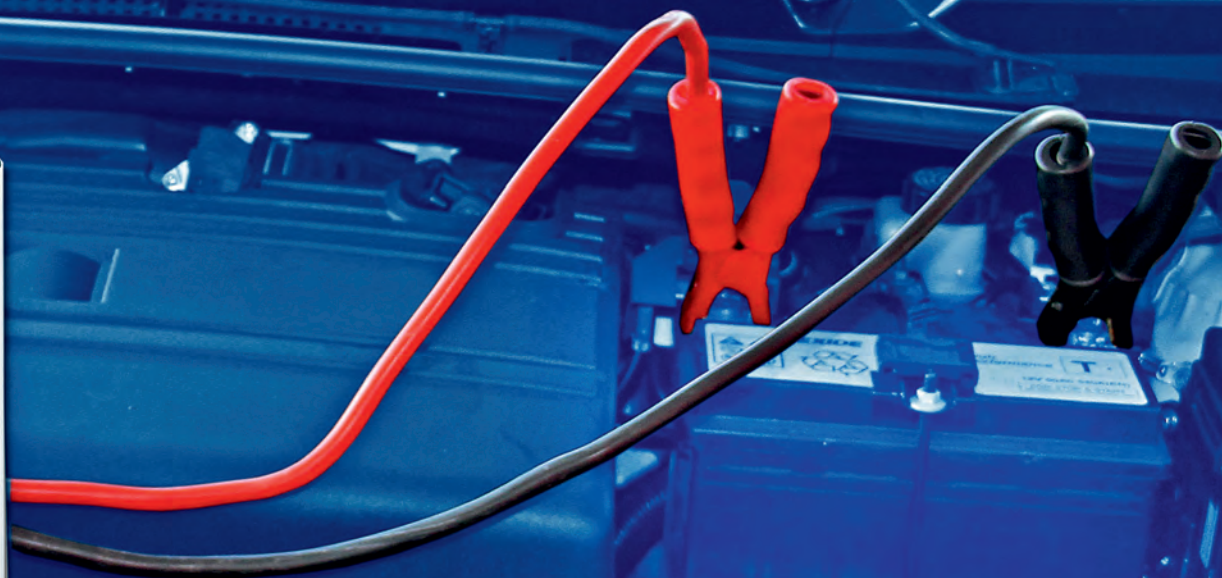



F-1900

12 V 400 A
1000 A pico / peak

 12 V - 17 Ah

 16 mm²

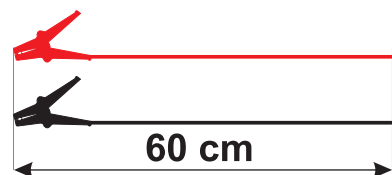

 400 A

 9,350 kg

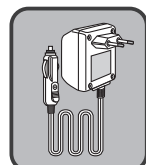
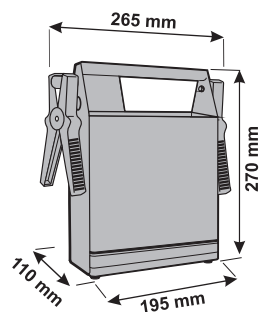

- Accesorios incluidos
- Free accessories
- Accessoires gratuits
- Gratis - Zubehör
- Gratis toebehoren

 12V

 400A

 LED
+150 h



F-2000

12 V 400 A
1000 A pico / peak

 12 V - 17 Ah

 25 mm²

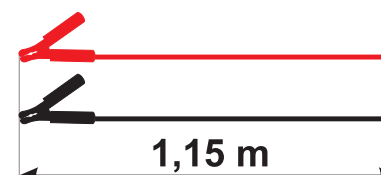

 600 A

 10,480 kg

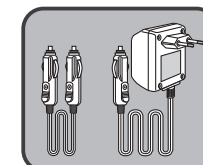
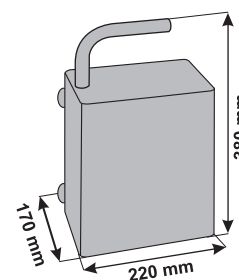

- Accesorios incluidos
- Free accessories
- Accessoires gratuits
- Gratis - Zubehör
- Gratis toebehoren

 12V

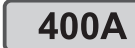
 400A



FERVE F-2000
BATTERY BOOSTER · 400 A

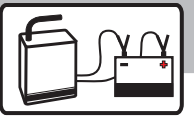

F-2001

12 V 600 A

1500 A pico / peak

 12 V - 28 Ah

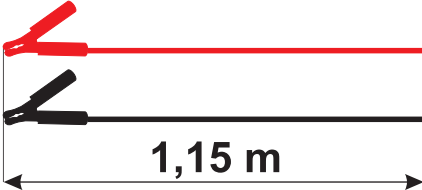

 25 mm²

 1,15 m

 600 A

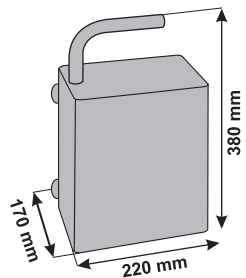
 14,700 kg



 12V
 600A

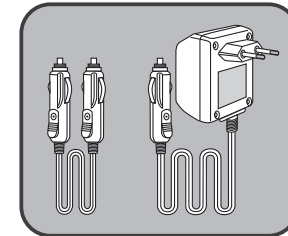

- Accesorios incluidos
- Free accessories
- Accessoires gratuits
- Gratis - Zubehör
- Gratis toebehoren





F-2024

24 V 600 A

1500 A pico / peak

 2 x 12 V - 28 Ah

 25 mm²

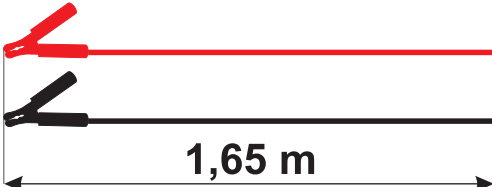
 1,65 m

 600 A

 29,400 kg

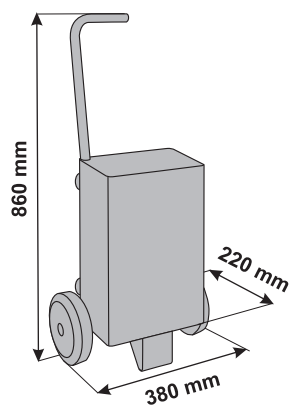

 24V

 600A

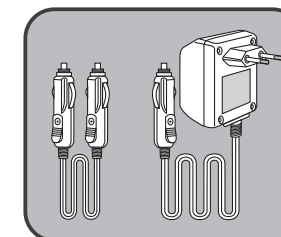

- Accesorios incluidos
- Free accessories
- Accessoires gratuits
- Gratis - Zubehör
- Gratis toebehoren



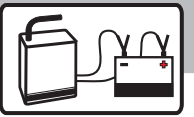

F-2050

24 V 800 A

2000 A pico / peak

 2 x 12 V - 42 Ah

 50 mm²

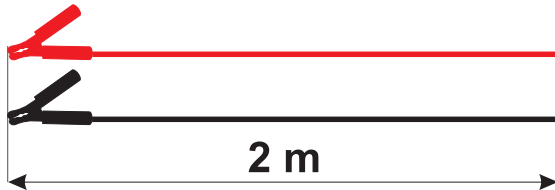

 800 A

 50,650 kg

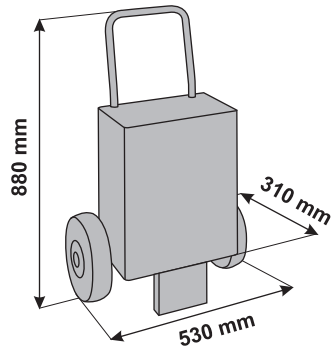

- Cargador automático de baterías interno
- Internal automatic battery charger
- Chargeur automatique de batteries interne
- Internes automatische Batterieladegerät
- Interne automatische acculader

 24V

800A





F-2124

12 V 1200 A (3000 A pico / peak)

24 V 600 A (1500 A pico / peak)

 2 x 12 V - 28 Ah

 35 mm²

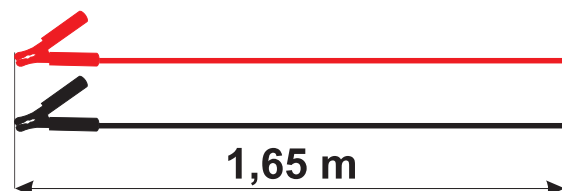

 600 A

 32,250 kg

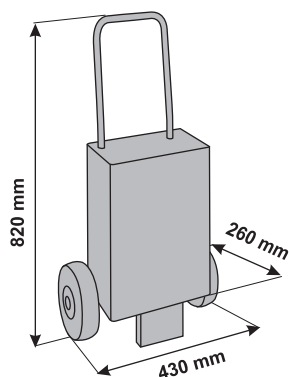

- Cargador automático de baterías interno
- Internal automatic battery charger
- Chargeur automatique de batteries interne
- Internes automatische Batterieladegerät
- Interne automatische acculader

 12-24V

12V - 1200A

24V - 600A

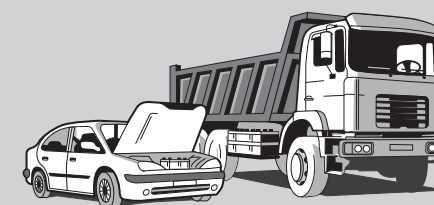

12V

1200A

24V

600A



FERVE

HOLD

MAX 1000A
800V CAT II
800V CAT III

1000A OFF
400A

V~ V- Ω Hz

ΔZERO

SELECT

AC/DC CLAMP METER F1707

25.39

°C

COM

VO-Hz

MAX 600V



F-2400

90 x 60 x 28 mm
0,135 kg

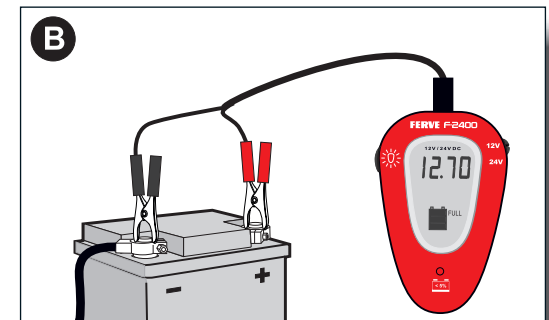
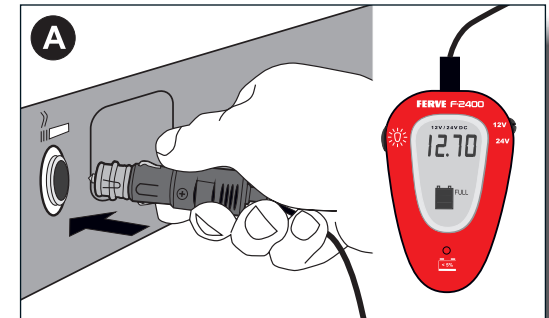



F-1902

119 x 68 x 19 mm
0,180 kg

FUNCTIONS	RANGE
Battery	12 V
Ah	25 - 200
Starting	12 V
Charging system	12 V



CE

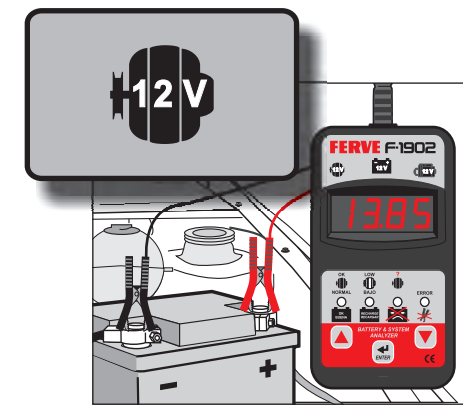
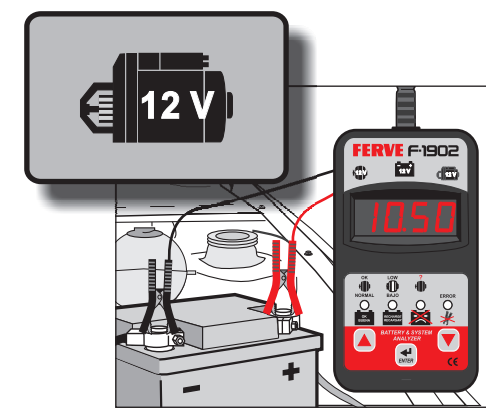
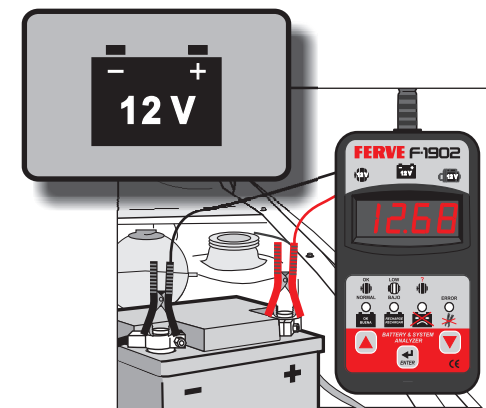

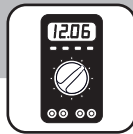

F-1800

200 x 115 x 50 mm
0,700 kg

FUNCTIONS	RANGE
Battery	6 - 12 V
Ah	25 - 300
SAE	40 - 2000
JIS	26A19 245H52
EN	40 - 2100
IEC	30 - 1500
DIN	25 - 1300
Starting	12 - 24 V
Charging system	12 - 24 V

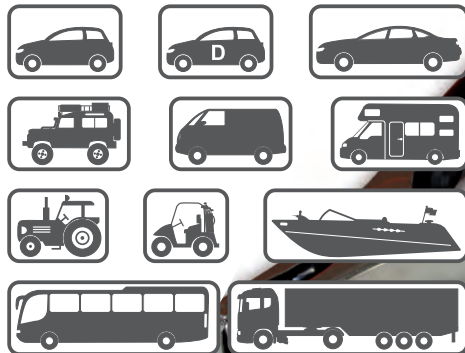
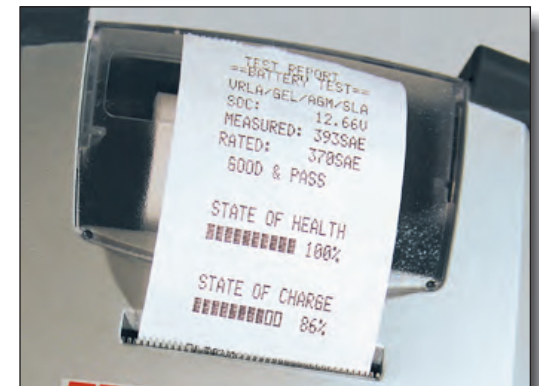
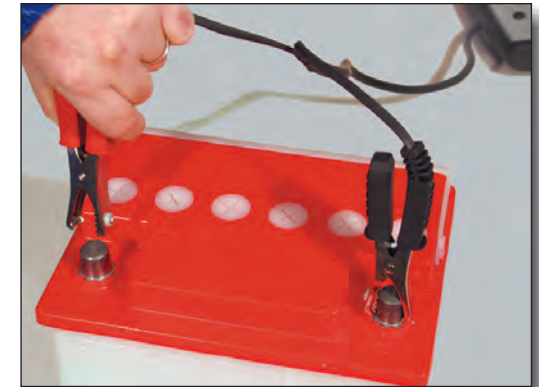

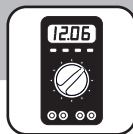

F-1830

138 x 69 x 31 mm
0,300 kg

1:1

FUNCTIONS	RANGE
DC Volts	0 V / 600 V
AC Volts	0 V / 600 V
DC Amps	0 A / 10 A
Ohms	0 Ω / 2 MΩ
Diode check	Yes
Continuity	Yes

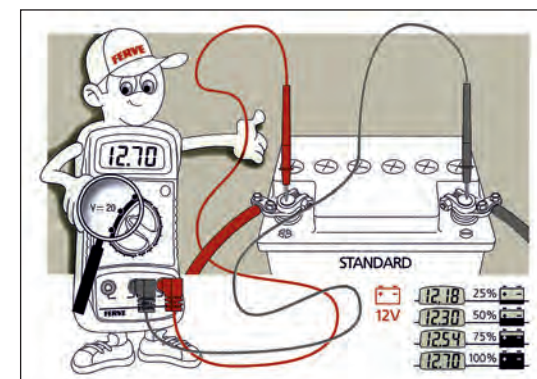
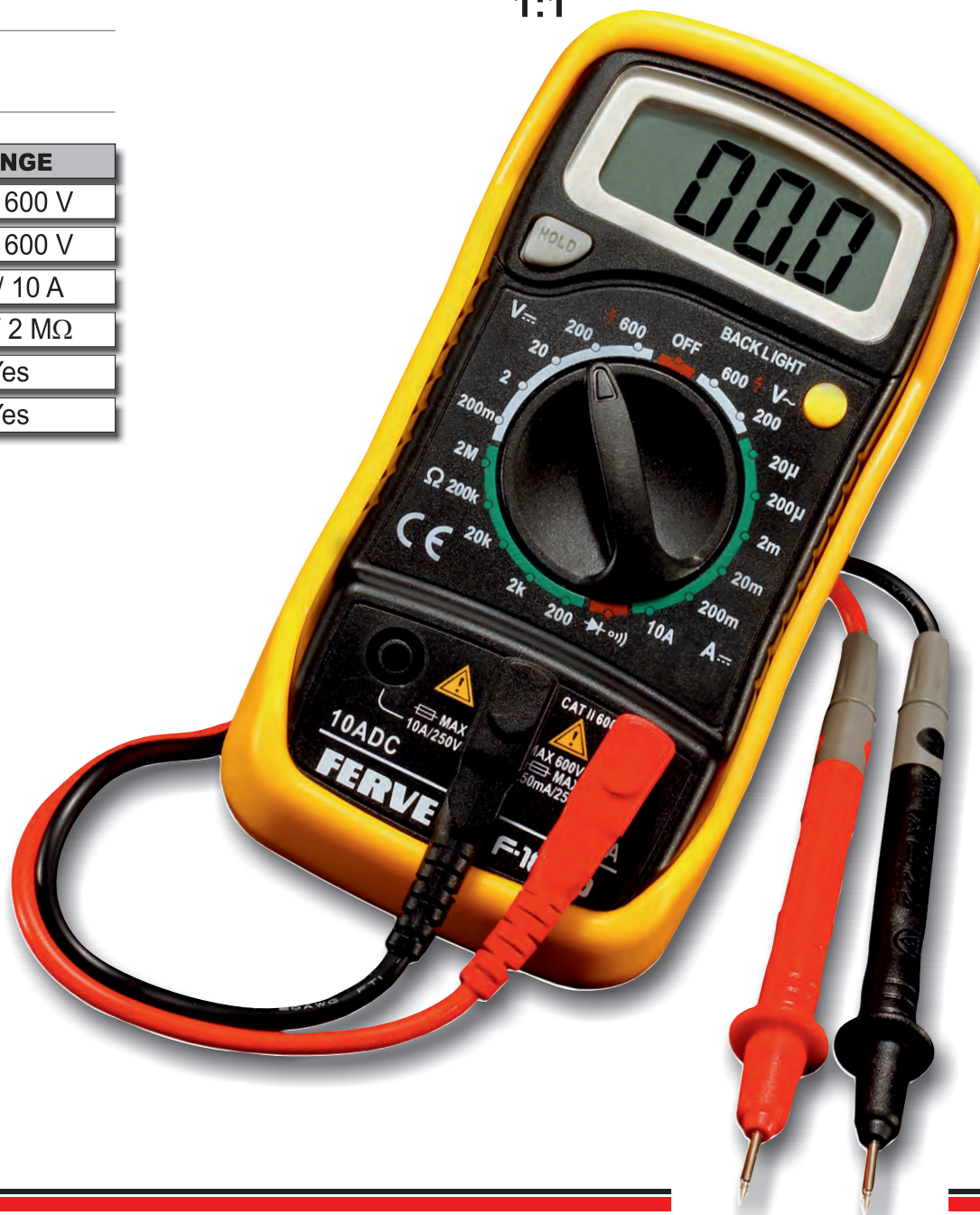

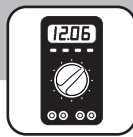

F-1860

200 x 95 x 55 mm
0,720 kg

FUNCTIONS	RANGE
DC Volts	0 V / 1000 V
AC Volts	0 V / 750 V
DC Amps	0 A / 20 A
AC Amps	0 A / 20 A
Ohms	0 Ω / 40 MΩ
Diode check	Yes
Continuity	Yes
Dwell angle	0° / 90°
Duty cycle	0% / 90%
Temperature	-50°C / 1100°C
Sensor type K	-50°F / 2000°F
Tachometer	1 / 12000 rpm
Frequency	0.01 Hz / 400 KHz
Capacitance	1 pF / 40 μF
Trigger	0.1 ms / 10 ms

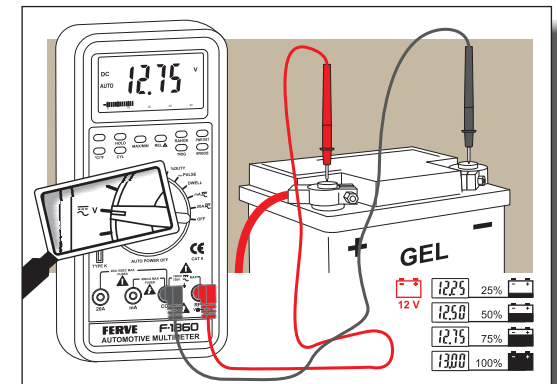
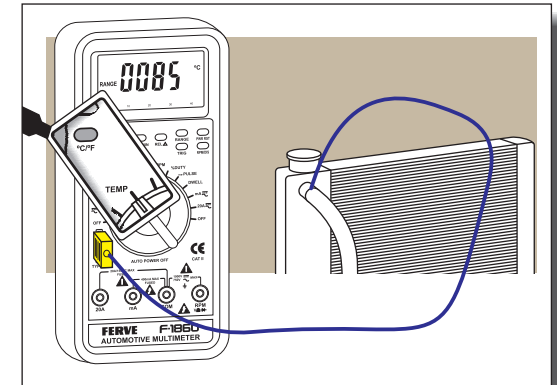



F-1707

250 x 100 x 44 mm
0,450 kg

FUNCTIONS	RANGE
DC Amps	400A
	1000A
AC Amps	400A
	1000A
DC Volts	0.4V/4V/40V/400V
	1000V
AC Volts	4V/40V/400V
	700V
Ohms	400Ω/4kΩ/40kΩ/400kΩ/4MΩ
	40MΩ
Capacitance	4nF/40nF/400nF/4μF/40μF
Frequency	40Hz/400Hz/4kHz/40kHz/100kHz
Temperature	400°C ~ 750°C
	0°C ~ 400°C
	-40°C ~ 0°C

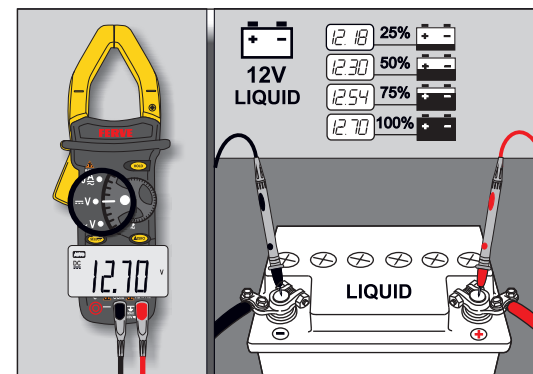
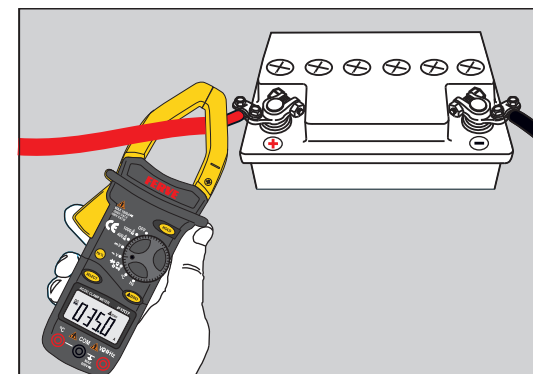

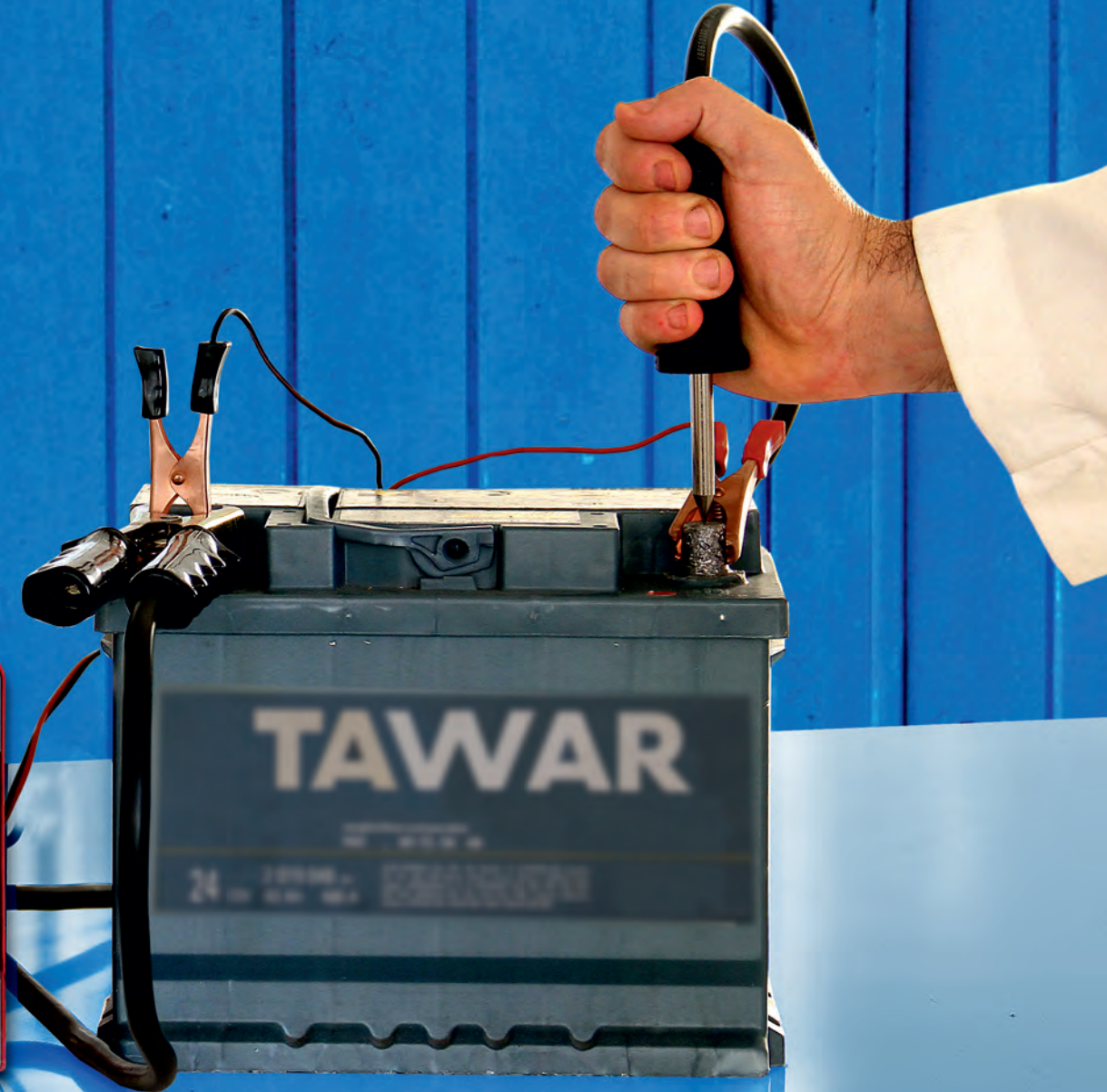

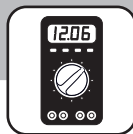

F-814 E

12 V 32 180 Ah

Descarga 250 A
Discharge 250 A

250 x 145 x 210 mm
3,350 kg

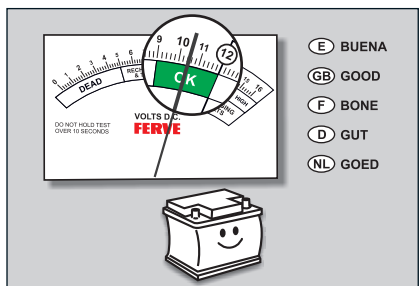
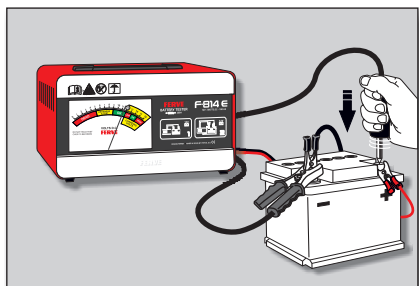



F-814

12 V  32  180 Ah

Descarga 250 A
Discharge 250 A

250 x 145 x 210 mm
3,350 kg

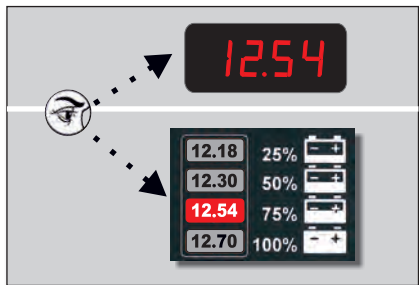
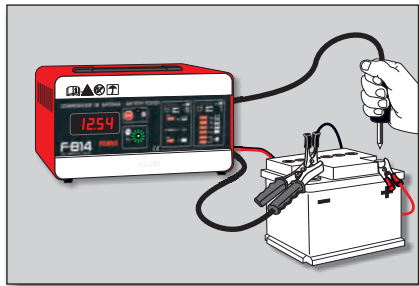



F-416 · 12V

140 x Ø 15 mm
0,025 kg



F-416 · 24V

140 x Ø 15 mm
0,025 kg



F-30 (2,8 · 48V)

160 x 22 x 16 mm
0,030 kg



F-91

160 x 22 x 16 mm
0,030 kg



F-916 (6 · 12 · 24V)

160 x 22 x 16 mm
0,030 kg





F-85

120 x 23 x 15 mm
0,180 kg



F-2200

180 x 30 x 18 mm
0,070 kg



F-90

160 x 43 x 15 mm
0,125 kg

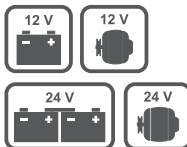

F-88

112 x 36 x 16 mm
0,029 kg

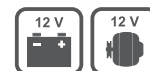



F-410 B

25 A

175 x 110 mm
0,050 kg

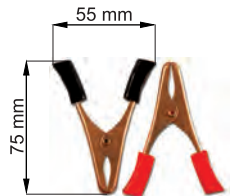

F-427 B

75 A

220 x 140 mm
0,125 kg

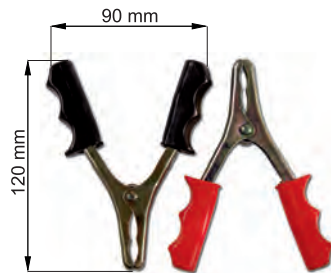

F-444 B

200 A

285 x 150 mm
0,250 kg

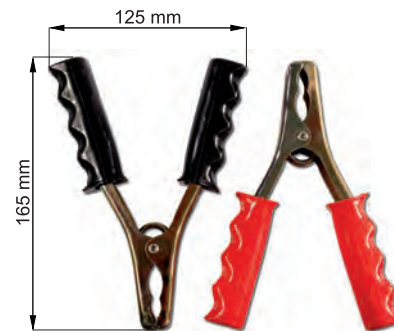

F-600 B

600 A

300 x 165 mm
0,500 kg





F-402 (20)
10 A



F-410 (20)
25 A



F-427 (10)
75 A



F-444 (10)
200 A



F-600 (4)
600 A



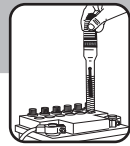

F-425

245 mm
0,030 kg



F-425 C

250 x 32 x 32 mm
0,050 kg



F-432

130 x 110 x 30 mm
0,140 kg



F-211

300 mm
0,050 kg

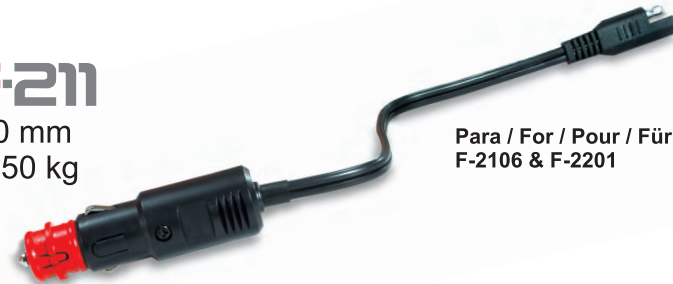

Para / For / Pour / Für / Voor
F-2106 & F-2201

F-438

225 x 100 mm
0,100 kg
Capacidad 1 litro
Capacity 1 liter
Capacité 1 litre
Inhalt 1 Liter
Inhold 1 liter



F-95 / 4

110 x 150 mm
0,060 kg

FERVE
Pic



F-300 AL / TO F-306

8 x 13 mm
0,025 kg

FERVE
Pic



F-300 F-302 F-304 F-306

FERVE ROLL-FLEX

100% cobre
100% copper
100% cuivre
100% Kupfer
100% koper

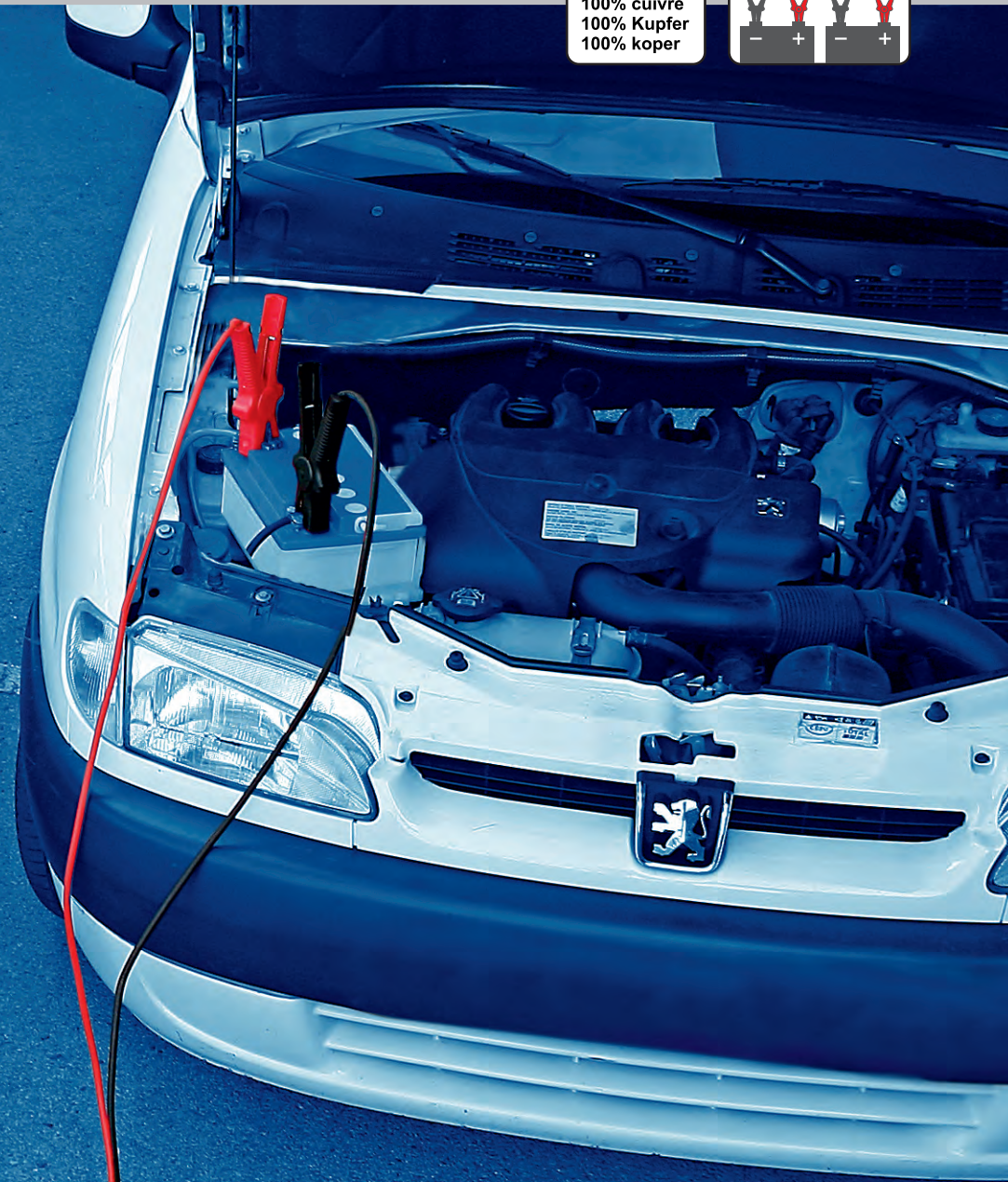
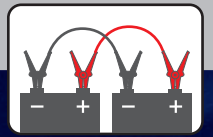

100% cobre
100% copper
100% cuivre
100% Kupfer
100% koper

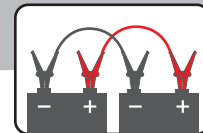

F-540

150 A

10 mm²

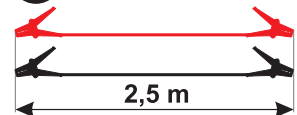

1,110 kg

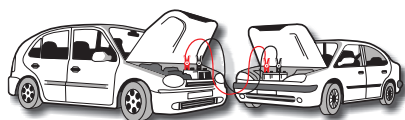

F-445

220 A

16 mm²

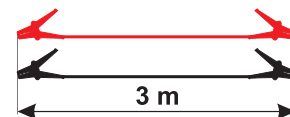

1,520 kg

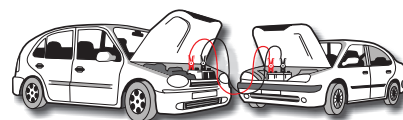

F-945

220 A

16 mm²

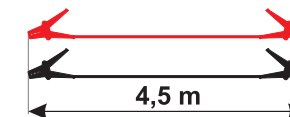

2,050 kg

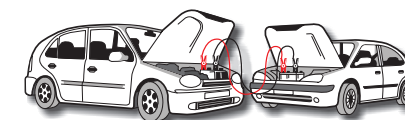

100% cobre
100% copper
100% cuivre
100% Kupfer
100% koper

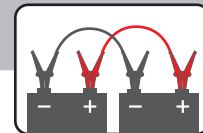

F-950

350 A

 25 mm²

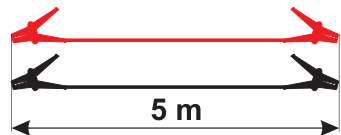

3,560 kg

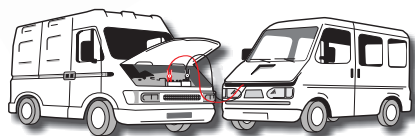

F-960

480 A

 35 mm²

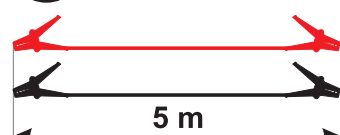

4,800 kg

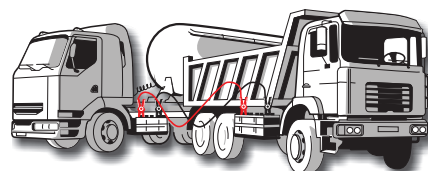

F-980

700 A

 50 mm²

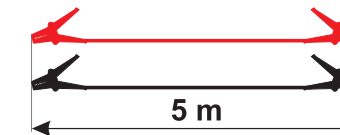

6,250 kg

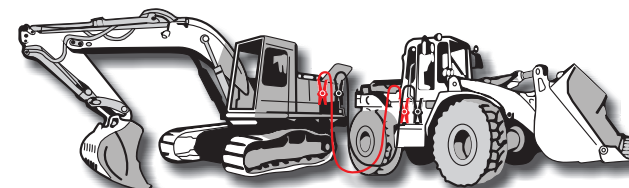



- Atención on-line de consultas técnicas
- Online technical support
- Service en ligne de demandes d'informations techniques
- Online-Hilfe bei technischen Fragen
- On-line technisch consult



- Catálogo continuamente actualizado
- Continually updated catalogue
- Catalogue constamment actualisé
- Laufend aktualisierter Katalog
- Voortdurend bijgewerkte catalogus

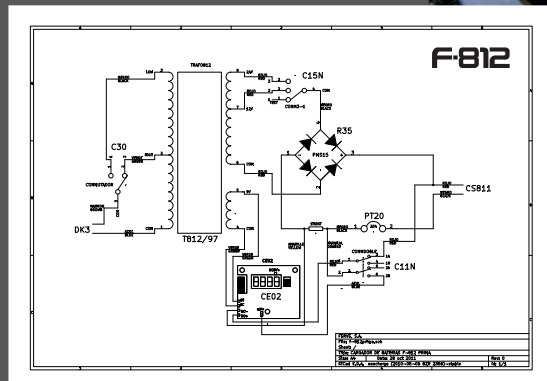

- Hojas de reparación con códigos de recambio
- Repair sheets with spare part codes
- Fiches de réparation avec codes de pièces de rechange
- Reparaturanleitungen mit Ersatzteilnummern
- Reparatiebladen met codes van wisselstukken

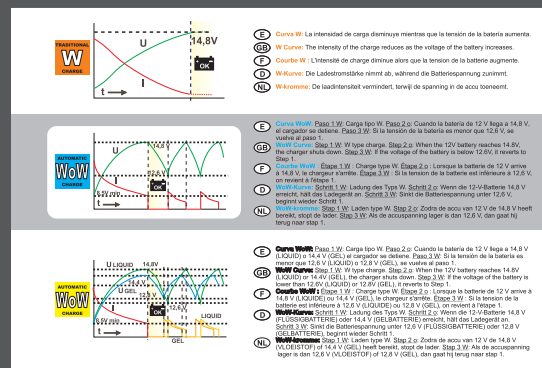

- Curvas de carga
- Charge curves
- Courbes de charge
- Ladekurven
- Belastingskrommen

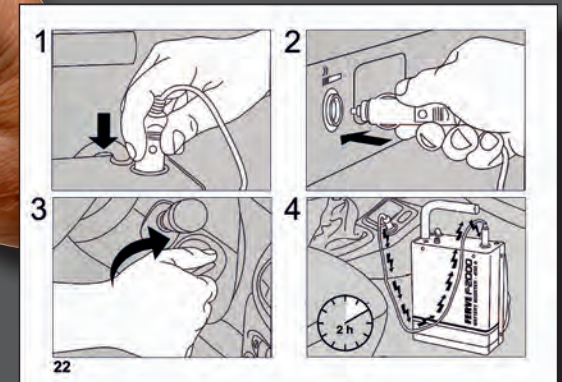

- Instrucciones totalmente ilustradas
- Fully illustrated instructions
- Instructions totalement illustrées
- Vollständig illustrierte Bedienungsanleitungen
- Volledig geïllustreerde handleiding





Los cargadores y comprobadores de baterías FERVE cumplen las directivas 73/23/EEC y RoHS 2002/95/EC, así como las normas EN 60335-1 y EN 60335-2-29.

Reservados todos los derechos. Prohibida la reproducción total o parcial sin consentimiento escrito de FERVE, S.A.

FERVE, S.A. se reserva el derecho de modificar los productos del presente catálogo sin previo aviso.

The FERVE battery chargers and testers comply with the directives 73/23/EEC and RoHS 2002/95/EC, as well as with the norms EN 60335-1 and EN 60335-2-29.

All rights reserved. No parts of this catalogue may be totally or partially reproduced without prior permission in writing of FERVE, S.A.

FERVE, S.A. reserves the right to modify the products of this catalogue without prior notice.

FERVE ON-LINE

General / General

ferve@ferve.com

Consultas técnicas / Technical Queries

oftecnica@ferve.com

Ventas nacionales / National Sales

administracion@ferve.com

Ventas internacionales / International Sales

sales@ferve.com

Consultas / Inquiries

consultas@ferve.com

© Copyright FERVE, S.A. - Design Ferret - 2013
Depósito legal: B- -2013

FERVE, S.A.
Ctra. de Calafell, 15-25 - Apartado (P.O. Box) 7 - 43700 El Vendrell (España)
Tel. +34 977 660 500 - Fax +34 977 661 160
<http://www.ferve.com>

